

**XFLY-MODEL**

# 64MM RED HAWK

Overall Length: 960mm  
Wingspan: 750mm

操作手册

Instruction Manual

<http://www.xfly-model.com/>



---

## Must-read

---

### Warnings

Please read through the whole user manual carefully and follow the instructions strictly for product installation and operation. Improper operation may lead to product damage or property loss or even severe personal injury. Xfly-model and its distributors will not assume responsibility if damage or loss is caused by violating the instructions listed.

### Caution

This product is Not a toy! Flying experience is required by users. Beginners should only operate the product under the supervision of professionals.

This product is not intended for use by children under 14 years!

### Safety Precautions

This product is radio-controlled and subject to interference from other signal sources which may result in momentary loss of control or even crash. So please always keep a safe distance in all directions around your model in order to avoid unexpected collision or injury.

- NEVER operate your model with low transmitter batteries.
- Always operate your model in an open area with the sun behind you away from cars, traffic or people.
- Do not operate your model in bad weather such as wet weather, thunderstorm, strong wind or heavy snow.
- Always follow the instructions and pay attention to the warnings for this product and other associated devices you use (charger, rechargeable battery pack, etc.)
- Always keep all chemicals, small parts and electronic components out of reach of children.
- Do not expose the electronic components to moist environment in case of damage.
- This model kit contains small parts, plastic bags, and materials that can be harmful to children if swallowed.
- ALWAYS ensure the transmitter is turned ON with the throttle at its lowest setting before connecting model battery.

### Lithium-Polymer (Li-Po) Battery Use

Caution: Always follow the manufacturer's instructions for safe use and disposal of batteries. Improper use of Li-Po batteries may cause a fire, property damage, or severe injury.

- Do not use the battery that is swollen, or overcharged, or has been damaged. Keep in mind to discharge the battery to storage voltage (3.8-3.85V per cell) if they are not in use for a long time and as soon as possible after use for safe storage. Always store the battery at room temperature in a cool dry area to extend the lifespan of the battery. Do not store the battery in a car or expose it to direct sunlight. For maximum safety Xfly-Model recommends storing Li-Po batteries in a proper battery bunker, or sealed (not airtight) fire resistant container.
- Only use a Li-Po compatible charger to charge & discharge Li-Po batteries - NEVER try to use any other charger in case of personal injury and property damage.
- Do not discharge the Li-Po to below 3V per cell or irreversible damage can occur to the battery.
- NEVER leave charging battery unattended.
- Do not charge damaged battery - instead dispose of Li-Po batteries by fully discharging then taking to an appropriate disposal agent.

### Warning for Battery Charging

As stated previously ONLY use a Li-Po compatible charger to charge the battery. Be sure to read and understand the charger instruction manual carefully before charger use. Make sure battery is on a heat-resistant surface when being charged. It is highly recommended to place the Li-Po battery inside a fire-resistant charging bag readily available at hobby shops or online stores.

---

## \ Product Overview /

---

The XFly Model T-7A Red Hawk 64mm EDF jet is an easy-to-fly and versatile trainer jet for a wider variety of experienced pilots to enjoy — including those with limited EDF experience. The 4S-compatible brushless motor and 40-amp ESC that are matched to a 12-blade 64mm fan deliver an abundance of speed, thrust and a turbine-like sound compared to other models in its class.

Use the included fixed landing gear with steerable nose wheel to taxi, take off and land on paved, packed dirt or grass surfaces at large parks and fields. Or leave the landing gear off for more speed and vertical performance plus easy hand launches and landings on grass. With stability it's a scale jet that flies smooth and handles like a sport jet. Be the first at your flight field to own what is surely one of the best and rare EDF jets available today!

### Features

- Scale replica of the iconic aircraft flown by the U.S. Air Force for training and other missions.
- Powerful 4S-compatible outrunner motor with 12-blade 64mm fan delivers excellent top speed and vertical performance plus turbine-like sound.
- Excellent vertical performance and speed compared to other micro class EDF models.
- Fast and precise factory-installed digital servos with ball-link equipped linkages.
- Strong removable landing gears and steerable nose wheel.
- Convenient top hatch with clear canopy, cockpit detail and pilot figure.
- Lightweight yet strong and durable EPO construction.

---

## \ Catalogue /

---

Must-read .....	02	Trouble shooting .....	11
Product Overview .....	03	Spare Parts List .....	11
Product Packing List .....	04	User Manual of Brushless Speed Controller .....	12
Product Specifications .....	04		
Assembly Instructions .....	05		
Control Horns Installation .....	07		
Battery Installation .....	07		
CG Setting .....	07		
Control Surface Testing .....	08		
Stickers Diagram .....	09		
Dual Rate Setting .....	10		

## Product Packing List

Please check the below parts carefully before assembly. If anything appears missing or damaged, please contact your distributor in the first instance, or send us an email (support@xfly-model.com) and advise the item name or part number of the missing or damaged part(s). (Please refer to the spare parts list on Page 11 of this manual for full parts listing). Please note that different versions can sometimes include slightly different items inside the package.

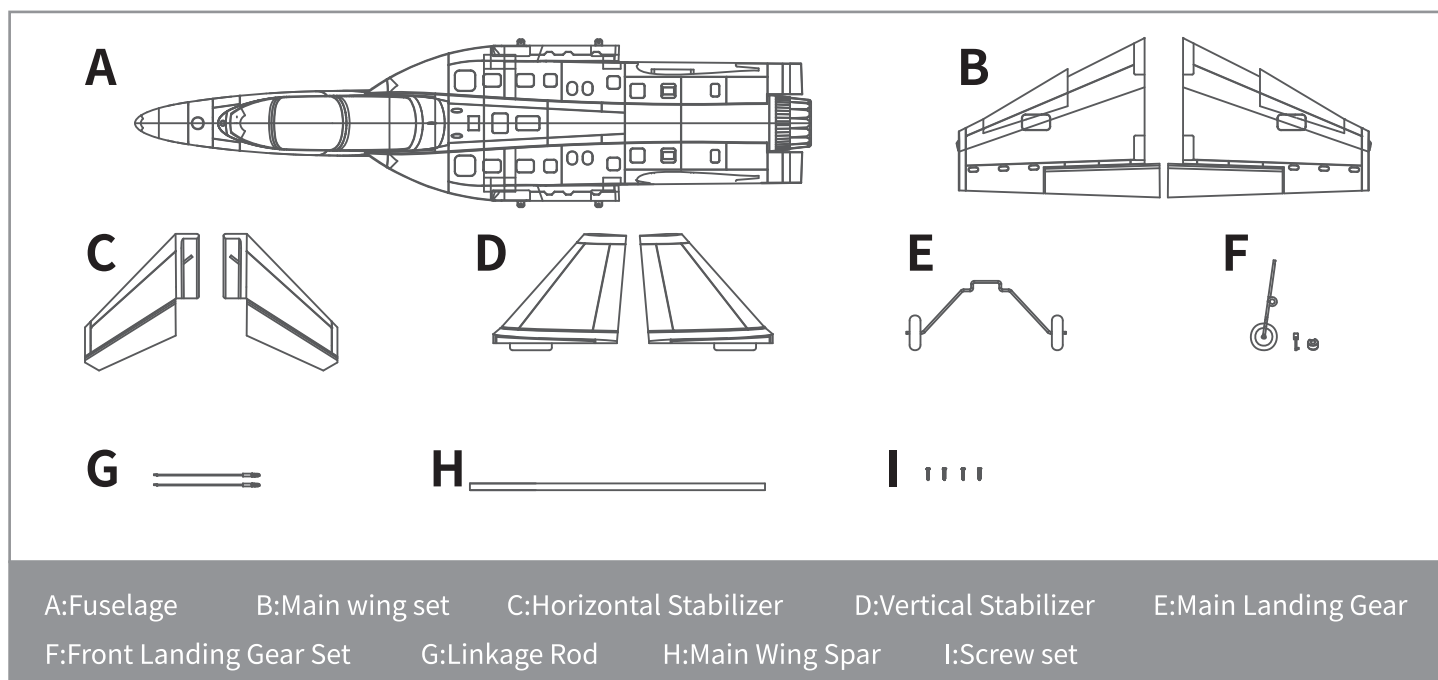

## Specifications

Material:	Lightweight yet strong EPO, ABS engineering plastics
Wingspan:	750mm
Overall Length:	960mm
Wing Load:	79g/dm <sup>2</sup>
Wing Area:	14.4dm <sup>2</sup>
Flying Weight:	1100g
Propeller/EDF:	64mm 12-Blade Fan
Motor:	2840-KV3200
ESC:	40A

Servos:	9g Digital Servo*5
Flying Duration:	8min
Landing Gear:	Fixed main landing gear, steerable nose gear
LED lights:	/
Channels:	4CH-Throttle, ailerons, elevator and steering front gear
Skill Level:	Intermediate/Advanced
Recommended Battery:	14.8V 2600mAh
Build&Test Time:	20min

## Main Wing Installation

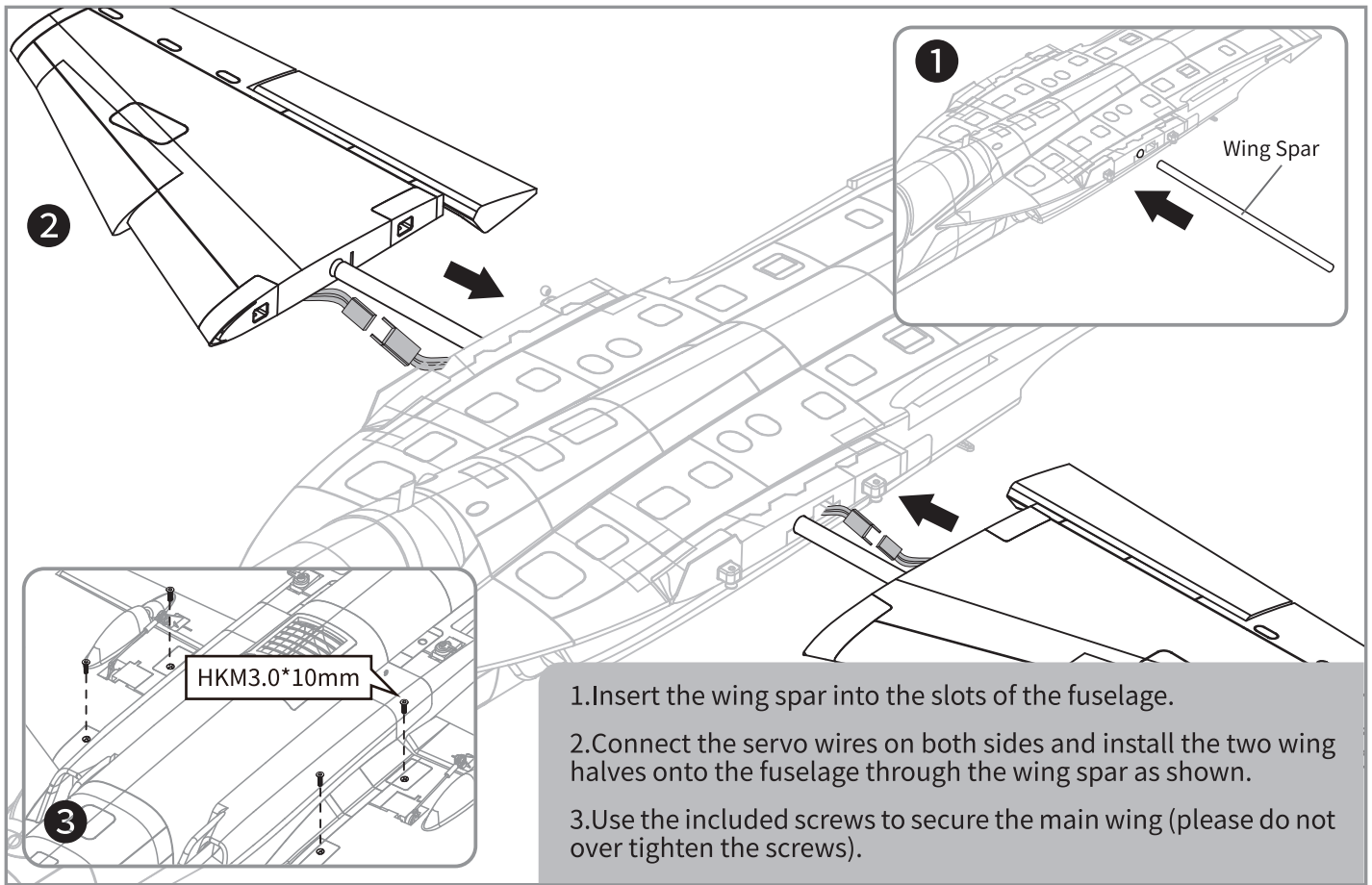

## Horizontal Stabilizer Installation

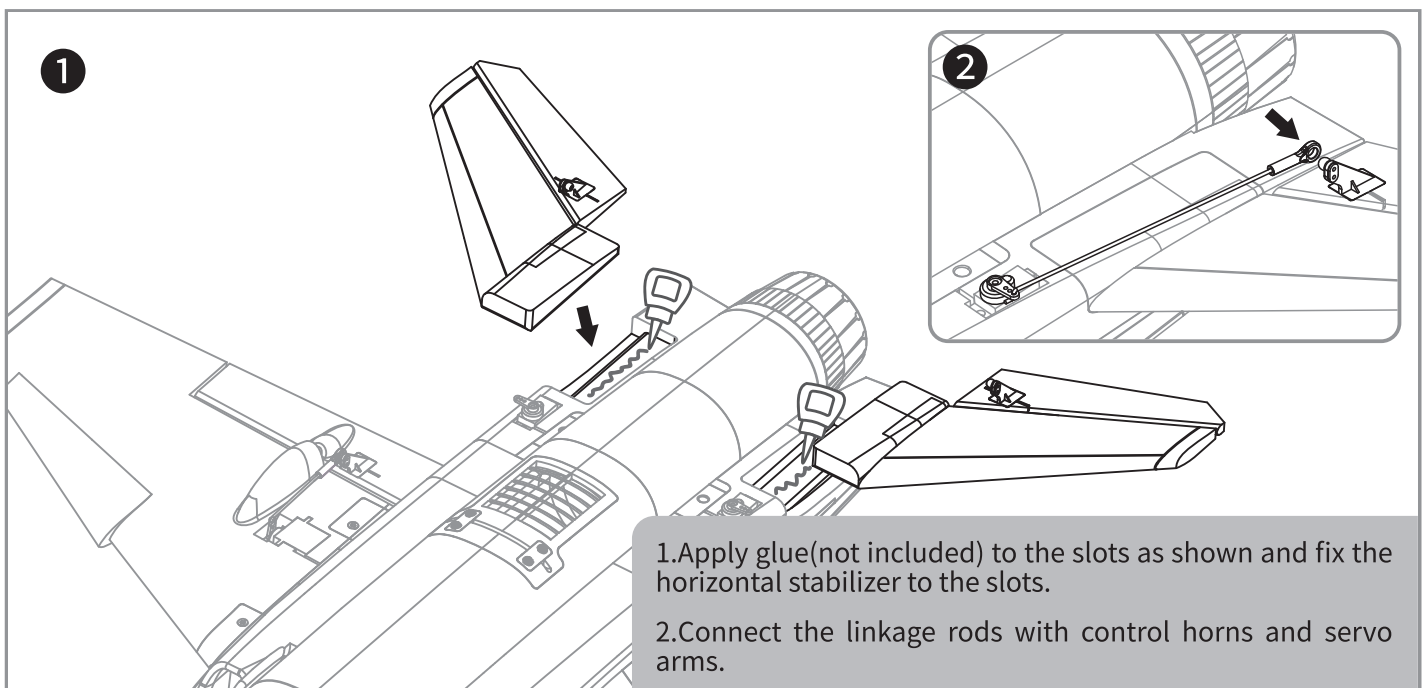

## Assembly Instructions

### Vertical Stabilizer Installation

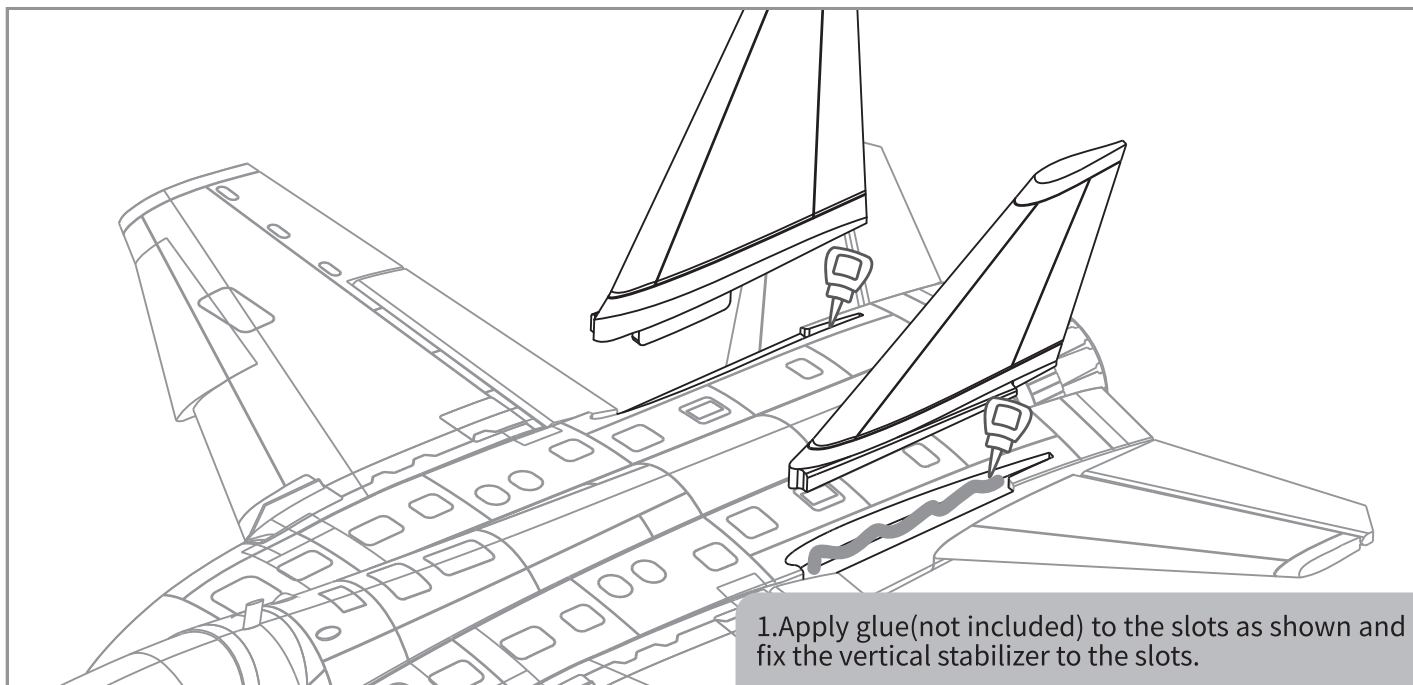

### Landing Gears Installation

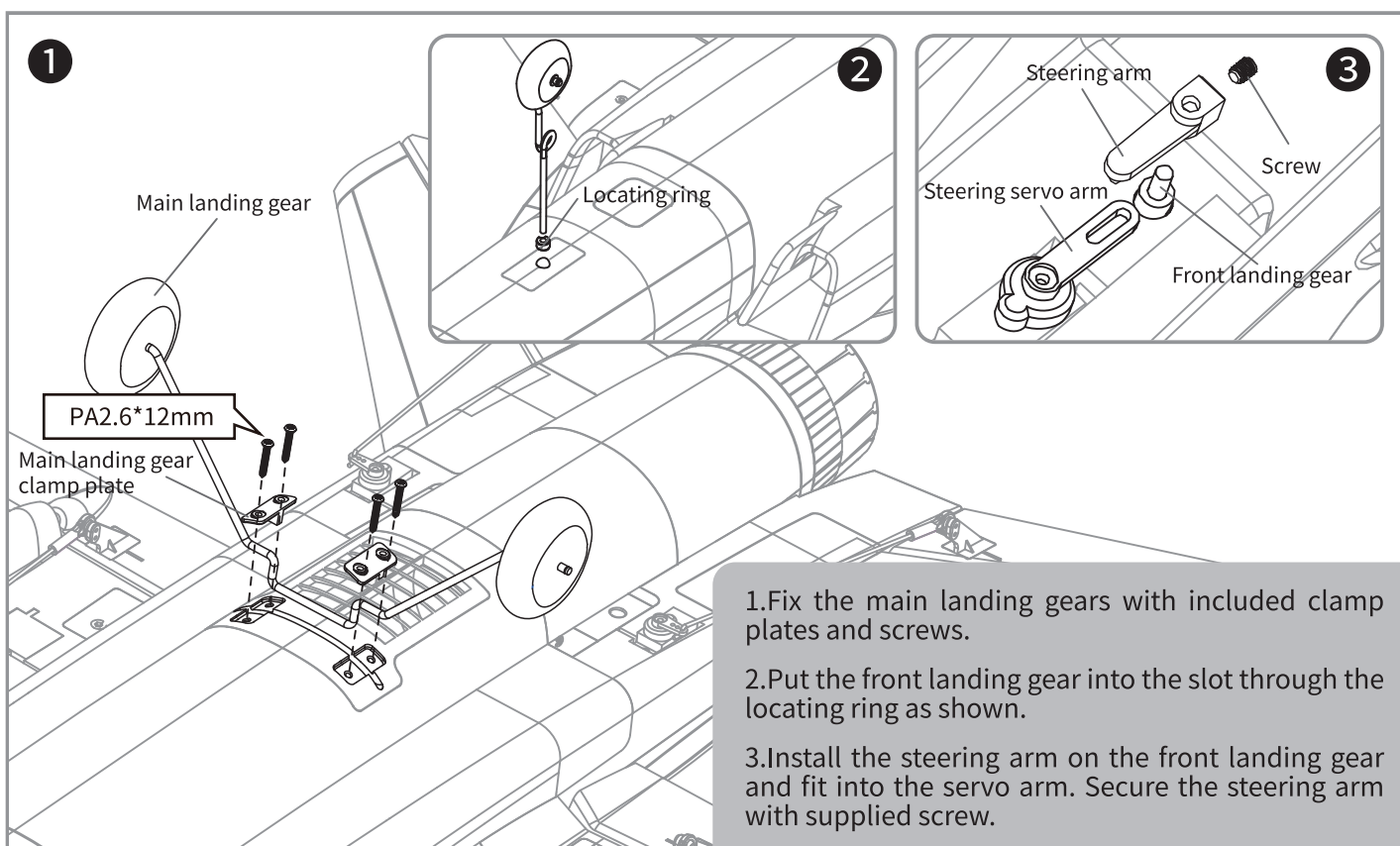

## Control Horns Installation

Make sure all servos are in their central position and adjust the linkages to the indicated positions.

The following pictures show the default factory settings for the control horns and linkages recommended for use for initial flight.

Hole reference for aileron flap servo linkage

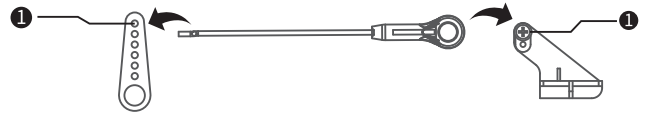

Hole reference for elevator servo linkage

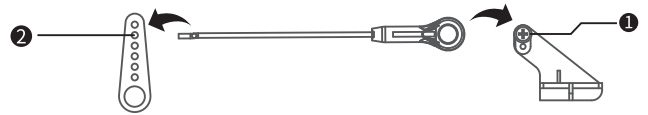

## Battery Installation

1. Before connecting the battery to the plane, power on the transmitter and ensure throttle lever in the lowest position.

2. Remove the battery hatch.

3. Insert battery into the battery compartment with the power cable towards the rear of the plane and use straps to secure the battery.

4. If necessary reposition battery to adjust the center of gravity (CG) by moving the battery forward or backward.

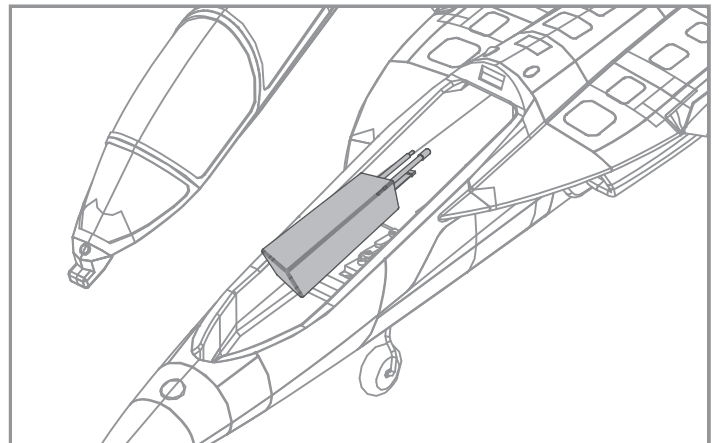

## CG Setting

**Correct center of gravity is very essential for a successful flight. Please refer to the below diagram to adjust the CG of the plane.**

— Adjust the CG position by moving the battery forwards or backwards. If necessary add ballast weight to achieve the correct CG position before flight.



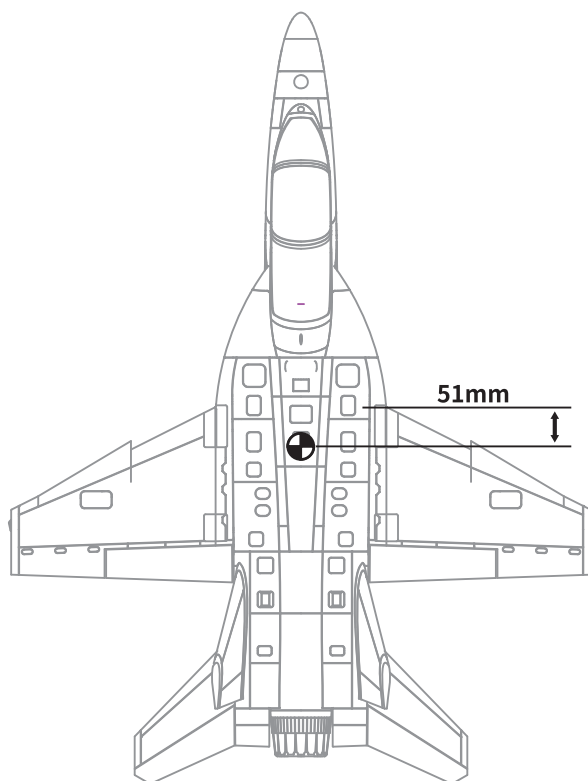

## Control Surface Testing

Before each flight turn on the transmitter BEFORE connecting a fully charged battery and perform a full pre-flight functional check-pay attention to all control surfaces for correct direction of operation.

Xfly-Model Strongly recommends you also perform a full range test prior to each flight!

Note: SAFETY FIRST!! Please remove the propeller(where applicable) before carrying out any pre-flight maintenance to the power system to prevent potential injury from unintended propeller operation.

**ALWAYS CHECK CONTROL SURFACE DIRECTION FROM BEHIND THE MODEL LOOKING FORWARD TO ENSURE CORRECT OPERATION**

Aileron control lever moving leftward

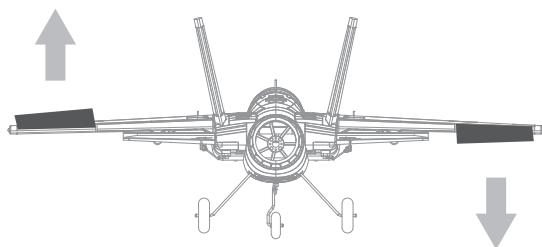

Aileron control lever moving rightward

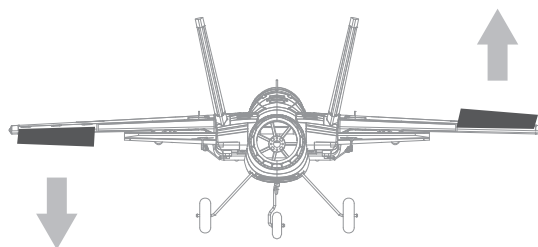

Elevator control lever moving downward

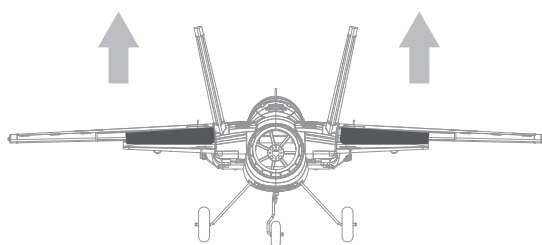

Elevator control lever moving upward

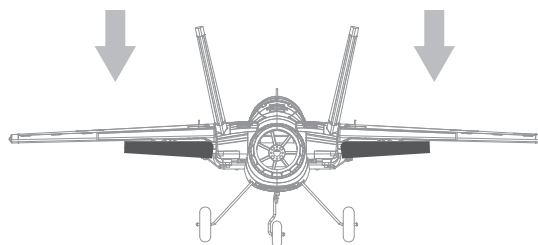

---

## Stickers Diagram

---

“NO STEP” small stickers are NOT factory-applied but included in the box for optional use. Customers can choose to put the small stickers on the plane according to this diagram.

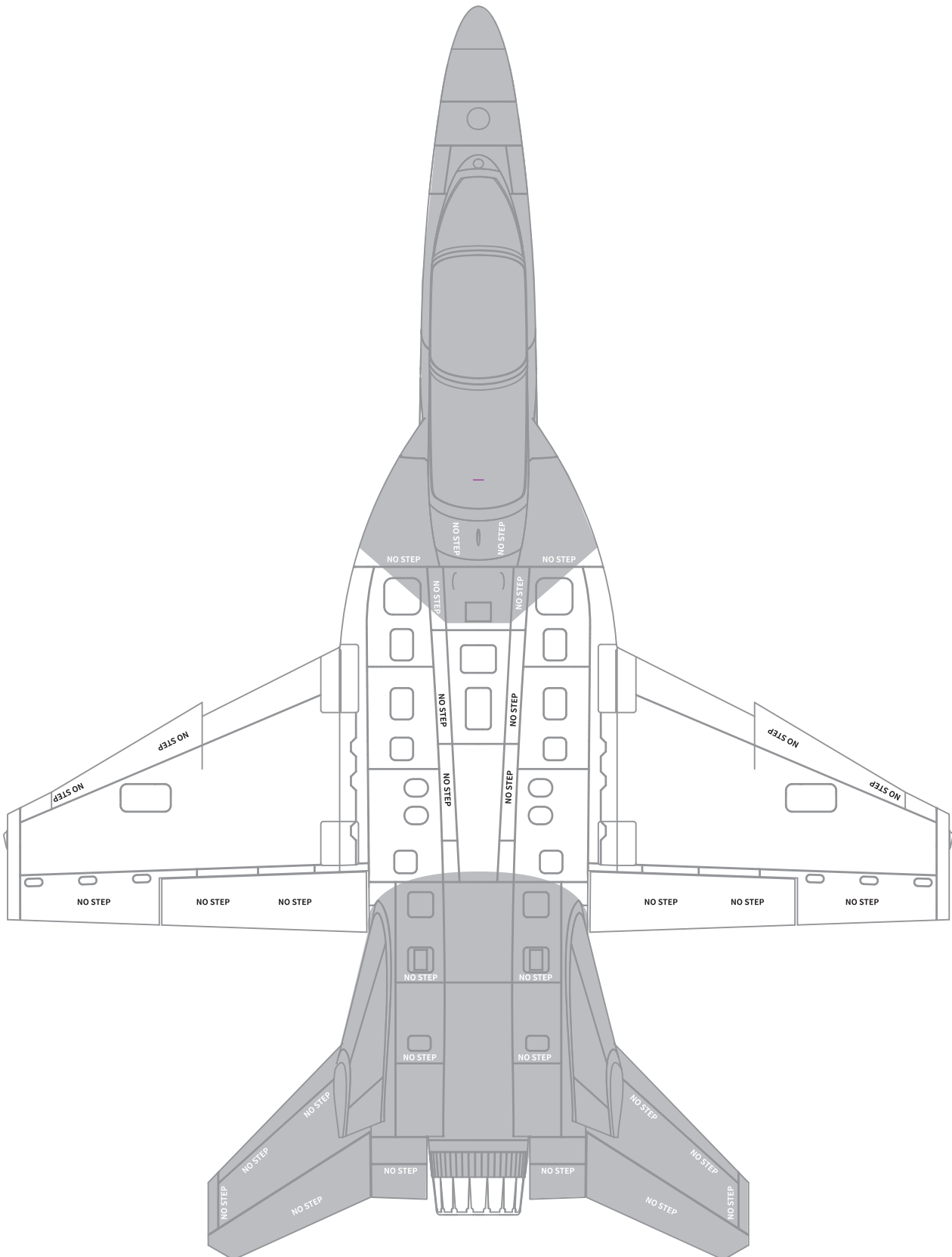

## Dual Rate Setting

Based on Xfly-Model's testing experience, the following rates are recommended for optimum performance. It is suggested that initial flights are carried out using low rates until you are comfortable with the flight characteristics of the plane.

### Aileron

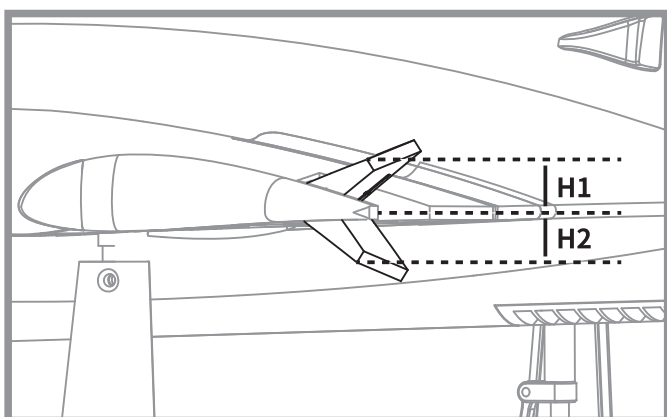

### Flap

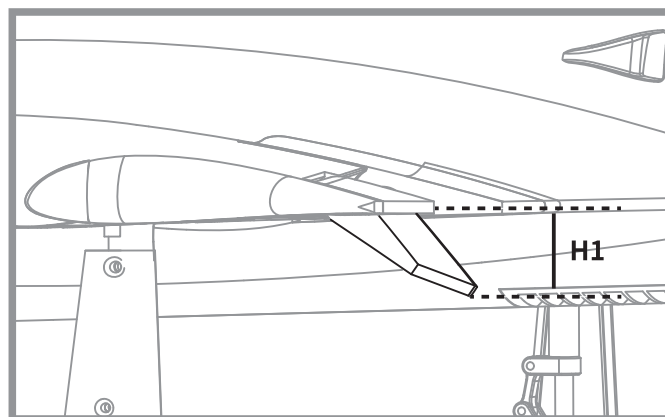

### Elevator

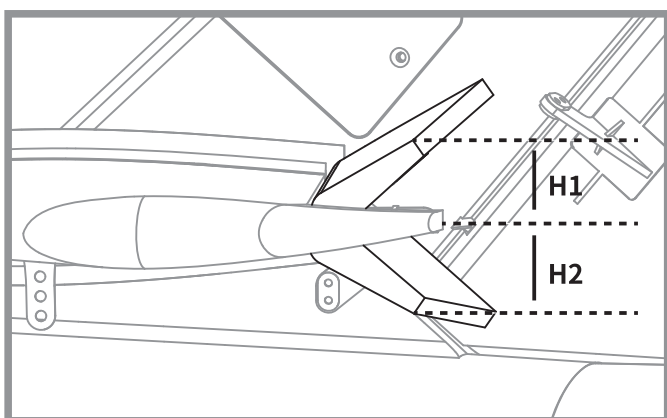

### Rudder

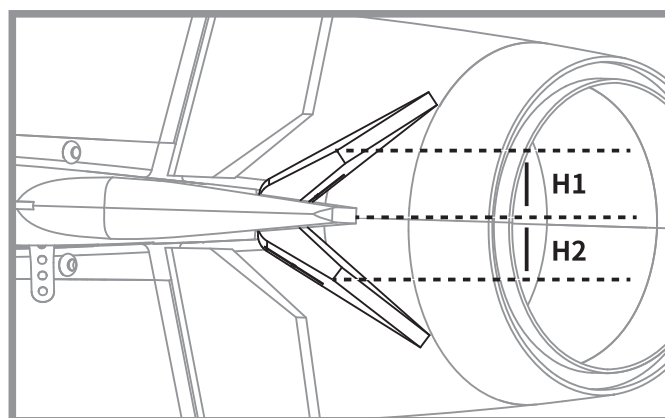

**Note:** When flaps are released, the aircraft will be heading up, so mixed elevator control is required for good landings. It requires 1mm height lower for high dual-rate flap and 2mm lower for low dual-rate flap.

	Aileron	Elevator	Rudder	Flaps
Low dual rate(H1/H2)	8mm	8mm	/	/
High dual rate(H1/H2)	12mm	12mm	/	/

## \ Trouble Shooting /

Problem	Possible Cause	Solution
Aircraft not responding to the throttle but responding to other controls	-ESC not calibrated -throttle deactivated on radio -motor wire disconnected	-Calibrate ESC according to manual -activate throttle on radio -check motor wires and connect/repair as required
Excessive propeller noise or Excessive vibration	-Propeller/EDF loose or damaged -Propeller/EDF out of balance -Propeller/EDF fan incorrectly installed or mounting loose	-Tighten and/or Replace damaged parts -balance propeller/EDF unit -Remove and install the propeller correctly -ensure mounting tight and parts correctly fitted
Reduced flight times or aircraft underpowered	-Low battery charge -ESC overheating -Defective battery	-Recharge battery -Ensure adequate cooling to ESC -Replace battery with new one
Control surface not moving, or responds slowly to control inputs	-Control surface, control horn, linkage or servo damaged -Wire damaged or connector loose	-Replace or repair damaged parts and adjust controls -Check all wires and ensure connections are secure -Repair/replace damaged wires or connectors
Control surface reversed	Channels reversed on the transmitter	-Check transmitter settings and adjust as required
Motor losing power in flight	-ESC not calibrated correctly -ESC LVC low voltage cutoff activated -Defective motor, ESC, or battery	-Recalibrate ESC -Check the battery, transmitter, receiver, ESC, motor and replace it if defective -Get the aircraft land immediately and recharge the battery
Slow LED flash on the receiver	Receiver power loss	-Check the connection between ESC and receiver -Check if servo is damaged -Check if the linkages are in place

## \ Spare Parts List /

XF103-01	Fuselage	XFKV3200	2840-KV3200 motor
XF103-02	Main Wing Set	XFESC40A	40A ESC
XF103-03	Horizontal Stabilizer	XFSER9PP	9g digital plastic-g geared servo positive
XF103-04	Vertical Stabilizer		
XF103-05	Cockpit		
XF103-06	Wheel Set		
XF103-07	Pipe		
XF103-08	Linkage Rod		
XF103-09	Screw Set		
XF103-10	Control Horns		
XF103-11	Landing Gear Set(front and rear)		
XF103-12	Decal Sheet		
XFPILOT002	Pilot 002		
XF-DF002	64mm ducted fan(12-blade)		

# User Manual of Brushless Speed Controller

Thanks for purchasing our Electronic Speed Controller (ESC). High power system for RC model is very dangerous, please read this manual carefully. In that we have no control over the correct use, installation, application, or maintenance of our products, no liability shall be assumed nor accepted for any damages, losses or costs resulting from the use of the product. Any claims arising from the operating, failure or malfunctioning etc. will be denied. We assume no liability for personal injury, property damage or consequential damages resulting from our product or our workmanship. As far as is legally permitted, the obligation to compensation is limited to the invoice amount of the affected product.

## Specifications

Model	Cont Current	Burst Current	BEC Mode	BEC Output	Battery Cell	Weight	Size
Skywalker-6A	6A	8A	Linear	5V/0.8A	2S	5.5g	32*12*4.5
Skywalker-12A	12A	15A	Linear	5V/1A	2-3S	9g	38*18*6
Skywalker-12AE	12A	15A	Linear	5V/2A	2-3S	10g	38*18*7
Skywalker-15A	15A	20A	Linear	5V/2A	2-3S	16.5g	48*22.5*6
Skywalker-20A	20A	25A	Linear	5V/2A	2-3S	19g	42*25*8
Skywalker-30A	30A	40A	Linear	5V/2A	2-3S	37g	68*25*8
Skywalker-40A	40A	55A	Linear	5V/3A	2-3S	39g	68*25*8
Skywalker-40A-UBEC	40A	55A	Switch	5V/3A	2-4S	43g	65*25*12
Skywalker-50A-UBEC	50A	65A	Switch	5V/7A	3-6S	41g	65*29*10
Skywalker-50A-OPTO	50A	65A	N/A	N/A	3-6S	41g	65*29*10
Skywalker-60A-UBEC	60A	80A	Switch	5V/7A	3-6S	63g	77*35*14
Skywalker-60A-OPTO	60A	80A	N/A	N/A	3-6S	60g	77*35*14
Skywalker-80A-UBEC	80A	100A	Switch	5V/7A	3-6S	82g	86*38*12
Skywalker-80A-OPTO	80A	100A	N/A	N/A	3-6S	79g	86*38*12
Skywalker-100A-UBEC	100A	120A	Switch	5V/7A	3-6S	82g	86*38*12
Skywalker-100A-OPTO	100A	120A	N/A	N/A	3-6S	79g	86*38*12

## Programmable Items (The option written in bold font is the default setting)

- Brake Setting: Enabled / **Disabled**
- Battery Type: **Lipo** / NiMH
- Low Voltage Protection Mode(Cut-Off Mode): **Soft Cut-Off (Gradually reduce the output power)** /Cut-Off (Immediately stop the output power)
- Low Voltage Protection Threshold(Cut-Off Threshold): Low / **Medium** / High
  - For lithium battery, the battery cell number is calculated automatically. Low / medium / high cutoff voltage for each cell is: 2.85V/3.15V/3.3V. For example: For a 3S Lipo, when "Medium" cutoff threshold is set, the cut-off voltage will be:  $3.15 \times 3 = 9.45V$
  - For NiMH battery, low / medium / high cutoff voltages are 0%/50%/65% of the startup voltage (i.e. the initial voltage of battery pack), and 0% means the low voltage cut-off function is disabled. For example: For a 6 cells NiMH battery, fully charged voltage is  $1.44 \times 6 = 8.64V$ , when "Medium" cut-off threshold is set, the cut-off voltage will be:  $8.64 \times 50\% = 4.32V$ .
- Startup Mode: **Normal** /Soft /Super-Soft (300ms / 1.5s / 3s)
  - Normal mode is suitable for fixed-wing aircraft. Soft or Super-soft modes are suitable for helicopters. The initial acceleration of the Soft and Super-Soft modes are slower, it takes 1.5 second for Soft startup or 3 seconds for Super-Soft startup from initial throttle advance to full throttle. If the throttle is completely closed (throttle stick moved to bottom position) and opened again (throttle stick moved to top position) within 3 seconds after the first startup, the re-startup will be temporarily changed to normal mode to get rid of the chance of a crash caused by slow throttle response. This special design is suitable for aerobatic flight when quick throttle response is needed.
- Timing: **Low** / Medium / High,( 3.75° /15° /26.25° )  
Usually, low timing is suitable for most motors. To get higher speed, High timing value can be chosen.

## Begin To Use Your New ESC

**IMPORTANT!** Because different transmitter has different throttle range, please calibrate throttle range before flying.

**Throttle range setting (Throttle range should be reset whenever a new transmitter is being used)**

Switch on the transmitter, move throttle stick to the top position

Connect battery pack to the ESC, and wait for about 2 seconds

The "Beep-Beep-" tone should be emitted, means the top point of throttle range has been confirmed

Move throttle stick to the bottom position, several "beep-" tones should be emitted to present the amount of battery cells

A long "Beep-" tone should be emitted, means the lowest point of throttle range has been correctly confirmed

## Normal startup procedure

Move throttle stick to bottom position and then switch on transmitter.

Connect battery pack to ESC, special tone like "♪ 123" means power supply is OK

Several "beep-" tones should be emitted to present the amount of lithium battery cells

When self-test is finished, a long "beep-----" tone should be emitted

Move throttle stick upwards to go flying

### Protection Function

1. Start up failure protection: If the motor fails to start within 2 seconds of throttle application, the ESC will cut-off the output power. In this case, the throttle stick **MUST** be moved to the bottom again to restart the motor. (Such a situation happens in the following cases: The connection between ESC and motor is not reliable, the propeller or the motor is blocked, the gearbox is damaged, etc.)
2. Over-heat protection: When the temperature of the ESC is over about 110 Celsius degrees, the ESC will reduce the output power.
3. Throttle signal loss protection: The ESC will reduce the output power if throttle signal is lost for 1 second, further loss for 2 seconds will cause the output to be cut-off completely.

### Trouble Shooting

Trouble	Possible Reason	Action
After power on, motor does not work, no sound is emitted	The connection between battery pack and ESC is not correct	Check the power connection. Replace the connector.
After power on, motor does not work, such an alert tone is emitted: "beep-beep-, beep-beep-,beep-beep-" (Every "beep-beep-" has a time interval of about 1 second)	Input voltage is abnormal, too high or too low.	Check the voltage of battery pack
After power on, motor does not work, such an alert tone is emitted: "beep-, beep-, beep- "(Every "beep-" has a time interval of about 2 seconds)	Throttle signal is irregular	Check the receiver and transmitter Check the cable of throttle channel
After power on, motor does not work, such an alert tone is emitted: "beep-, beep-, beep-" (Every "beep-" has a time interval of about 0.25 second)	The throttle stick is not in the bottom (lowest) position	Move the throttle stick to bottom position
After power on, motor does not work, a special tone "♪ 567i2" is emitted after 2 beep tone (beep-beep-)	Direction of the throttle channel is reversed, so the ESC has entered the program mode	Set the direction of throttle channel correctly
The motor runs in the opposite direction	The connection between ESC and the motor need to be changed.	Swap any two wire connections between ESC and motor

### Program the ESC with your transmitter (4 Steps)

**Note:** Please make sure the throttle curve is set to 0 when the throttle stick is at bottom position and 100% for the top position.

1. Enter program mode
2. Select programmable items
3. Set item's value (Programmable value)
4. Exit program mode

#### 1. Enter program mode

- 1) Switch on transmitter, move throttle stick to top position, connect the battery pack to ESC
- 2) Wait for 2 seconds, the motor should emit special tone like "beep-beep-"
- 3) Wait for another 5 seconds, special tone like "♪ 567i2" should be emitted, which means program mode is entered



#### 2. Select programmable items

After entering program mode, you will hear 8 tones in a loop with the following sequence. If you move the throttle stick to bottom within 3 seconds after one kind of tones, this item will be selected.

1. "beep" brake (1 short tone)
2. "beep-beep-" battery type (2 short tone)
3. "beep-beep-beep-" cutoff mode (3 short tone)
4. "beep-beep-beep-beep-" cutoff threshold (4 short tone)
5. "beep-----" startup mode (1 long tone)
6. "beep-----beep-" timing (1 long 1 short)
7. "beep-----beep-beep-" set all to default (1 long 2 short)
8. "beep-----beep-----" exit (2 long tone)

**Note:** 1 long "beep-----" = 5 short "beep-"



#### 3. Set item value (Programmable value)

You will hear several tones in loop. Set the value matching to a tone by moving throttle stick to top when you hear the tone, then a special tone "♪ i5i5" emits, means the value is set and saved. (Keeping the throttle stick at top, you will go back to Step 2 and you can select other items; or moving the stick to bottom within 2 seconds will exit program mode directly)

Items	Tones	"beep-" 1 short tone	"beep-beep-" 2 short tones	"beep-beep-beep" 3 short tones
Brake		Off	On	
Battery type		Lipo	NiMH	
Cutoff mode		Soft-Cut	Cut-Off	
Cutoff threshold		Low	Medium	High
Start mode		Normal	Soft	Super soft
Timing		Low	Medium	High



#### 4. Exit program mode

There are 2 ways to exit program mode:

1. In step 3, after special tone "♪ i5i5", please move throttle stick to the bottom position within 2 seconds.
2. In step 2, after tone "beep-----beep-----"(that is: The item #8), move throttle stick to bottom within 3 seconds.

## \ 使用必读 /

### 警告

组装、调整及飞行前请务必认真阅读产品说明书以熟知产品的特性。请严格按照说明书提示进行飞机的组装、调整及飞行。如操作不当会造成产品本身损坏及其它财产损失,甚至造成严重的人身伤害。迅飞模型及其销售商,对于违反说明书的要求操作而造成的损失、将不负任何法律责任!

### 声明

模型不是玩具,具有一定的危险性,操作者需要具备一定的飞行经验,初学者请在专业人士指导下操作。飞机的使用年龄必须是14岁以上的儿童或者成人!

### 操作使用安全须知

本产品飞行由无线电遥控器控制,在飞行过程中可能会受到外界强信号源干扰而导致失控,甚至坠机。因此,在飞行过程中务必始终与飞机保持一定的安全距离,避免意外碰撞、受伤。

- 请勿在发射器电池低电量的情况下操纵模型飞机。
- 请勿在在公共场合、高压线密集区、高速公路附近、机场附近或者其它法律法规明确禁止飞行的场合飞行。
- 请勿在雷雨、大风、大雪或者其它恶劣气象环境下飞行。
- 请严格遵照产品指导说明及安全警告操作本产品及其相关配置(例如充电器、电池等)。
- 请勿将相关化工类产品、零部件、电子部件等置于儿童可触及的范围。
- 请勿将电子件暴露于潮湿的环境中,以免造成损坏。
- 请勿将本产品任意处置于口中,以免造成人身伤亡。
- 在任何情况下,都必须保证油门杆处于起始位、发射机处于打开状态时,才能连接模型飞机内部的动力电池。

### 锂聚合物电池使用安全须知

使用锂聚合物电池时,须严格遵守制造商说明、要求并了解相关风险,使用不当会导致锂聚合物电池起火,从而造成严重的财产损失甚至人身伤害。

- 禁止使用变形、胀气的锂聚合物电池。
- 禁止使用过充、放电的锂聚合物电池,避免发生危险。长时间不使用须将锂聚合物电池放电至存储电压(3.8~3.85V/节)。锂聚合物电池须储存在室内干燥区域(4.5~48.5°C),禁止将锂聚合物电池置于阳光下暴晒或车内,高温可能会导致锂聚合物电池起火,造成财产损失和人身伤害。
- 请使用专用充电器对锂聚合物电池进行充放电,禁止使用其它,如:镍氢电池充电器。充放电时,禁止将锂电池放置于高温物体表面,建议使用锂电池防爆袋。不正确的充放电操作会对锂聚合物电池造成损伤,甚至会引起火灾,造成财产损失和人身伤害。
- 禁止将锂聚合物电池单节电压放至低于 3V,禁止给已损坏的锂聚合物电池充电。
- 锂聚合物电池充放电须在有人看管的情况下进行,避免发生意外造成不必要的损失。
- 损坏或者报废处理的模型飞机电池,应妥善回收处理,不准随意抛弃,避免自燃而引发火灾。

### 飞机电池充电须知:

请确保使用合格的电池充电器给锂电池充电。在使用充电器前,请认真阅读充电器说明书。充电过程中,请确保把电池置于耐热的表面。建议把锂电池置于防火充电袋内充电,防火充电袋可在相关模型实体店或网上买到。

## \ 产 品 简 介 /

迅飞64mm T-7A红鹰,是一款操作简单但功能实用的涵道教练机,它适合各种飞行经验和水平的玩家。红鹰配备高性能的4S无刷外转电机和高质量的40A电调,在同等级别的涵道机中不管是速度,推力或是飞行声浪等方面都具有更优越的表现。

玩家可使用出厂安装好的起落架,让飞机在平坦的水泥路面,凹凸不平的泥地或草地上滑行、起飞和降落。或者拆卸起落架使用手抛方式起飞并在草地上着陆,这种方式不仅能使飞机获得更快的飞行速度和更好的垂直性能,并且可以增加飞行趣味。凭借稳定的飞行性能,T-7A红鹰不仅是一款像真涵道机,更是一款操控性出色的运动涵道机。

即刻抢先拥有这款新颖惊喜的教练涵道机吧!

### 特征

- 美国空军用于训练和其他任务的标志性像真飞机。
- 动力系统: 银河 X 系列 64mm12 叶 涵道, 2840-KV3200 4S 外转无刷电机, 搭配 40A 电调。
- 在同等级别的涵道机中, 具有更卓越的垂直性能、垂直速度和更出色的飞行声浪。
- 整机采用数码舵机, 搭配球头连接杆的控制, 使舵面可得到精准的响应。
- 整套起落架可通过螺丝安装或拆卸, 同时前轮可控制转向。
- 便捷拆卸式座舱, 透明的吸塑座舱罩和像真的飞行员人偶。

## \ 目 录 /

使用必读 .....	14	故障检修 .....	23
产品简介 .....	15	配件列表 .....	23
产品包装清单 .....	16	电调说明 .....	24
产品参数 .....	16		
产品组装说明 .....	17		
舵角摇臂安装 .....	19		
电池安装 .....	19		
重心调整 .....	19		
舵面测试 .....	20		
贴纸示意图 .....	21		
推荐舵面行程 .....	22		



## \ 产 品 包 装 清 单 /

在组装产品之前,请仔细检查以下配件,如有缺失或者损坏,请及时联系商家或者邮件至厂家(support@x-fly-model.com),告知缺失或损坏的配件名称及编码(请在本说明书尾页查看相应的配件编码)。请注意,不同配置,包装盒内部物品不同。

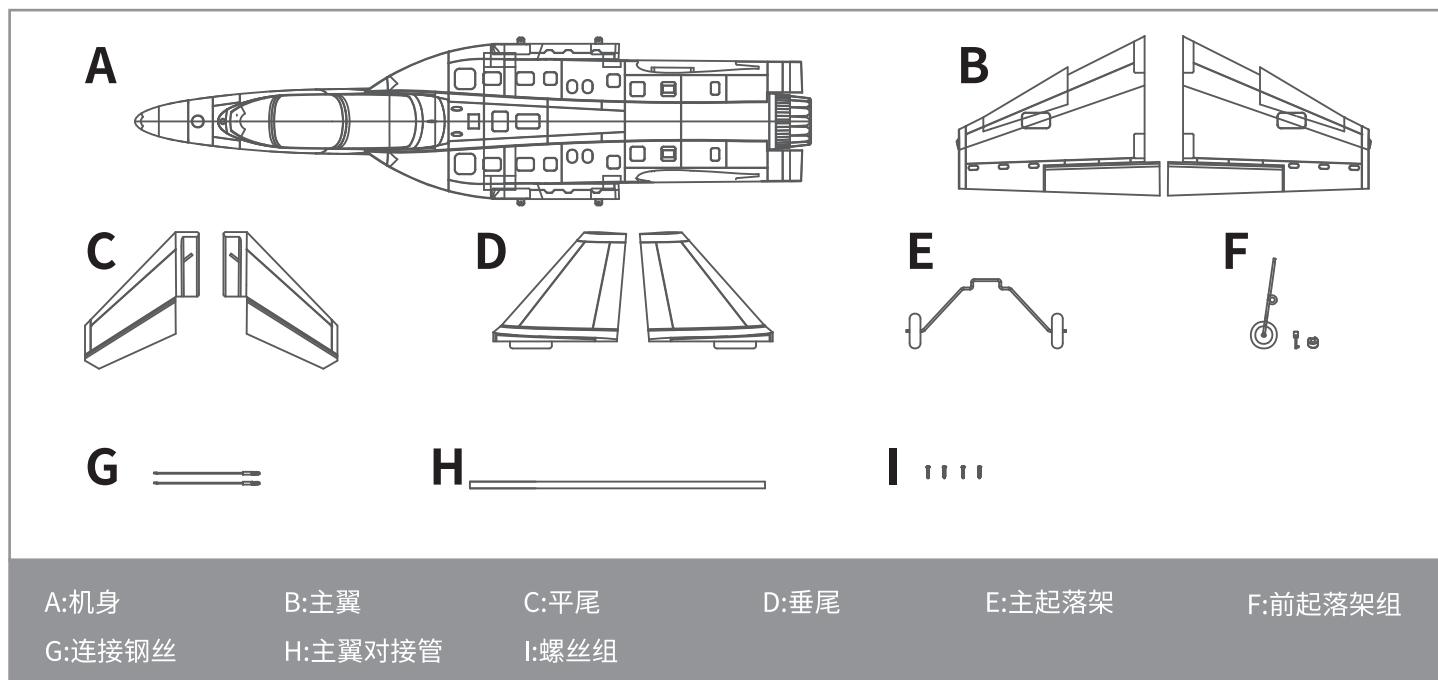

## \ 产 品 参 数 /

材料:	高密度 EPO, ABS 工程塑料
翼展:	750mm
机身长度:	960mm
翼载荷:	79g/dm <sup>2</sup>
机翼面积:	14.4dm <sup>2</sup>
起飞重量:	1100g
桨叶类型:	64mm 12 叶涵道
电机:	2840-KV3200
电调:	40A

舵机:	9g 数码舵机 *5
持续飞行时间:	8 分钟
起落架:	固定主起落架, 前轮可转向
舱门系统:	/
通道介绍:	4CH- 油门, 副翼, 平尾 / 升降舵, 前轮转向
模型难度:	初级进阶 / 中级经验水平
推荐锂电池:	14.8V 2600mAh
组装调试时长:	~20 分钟

## 主翼安装

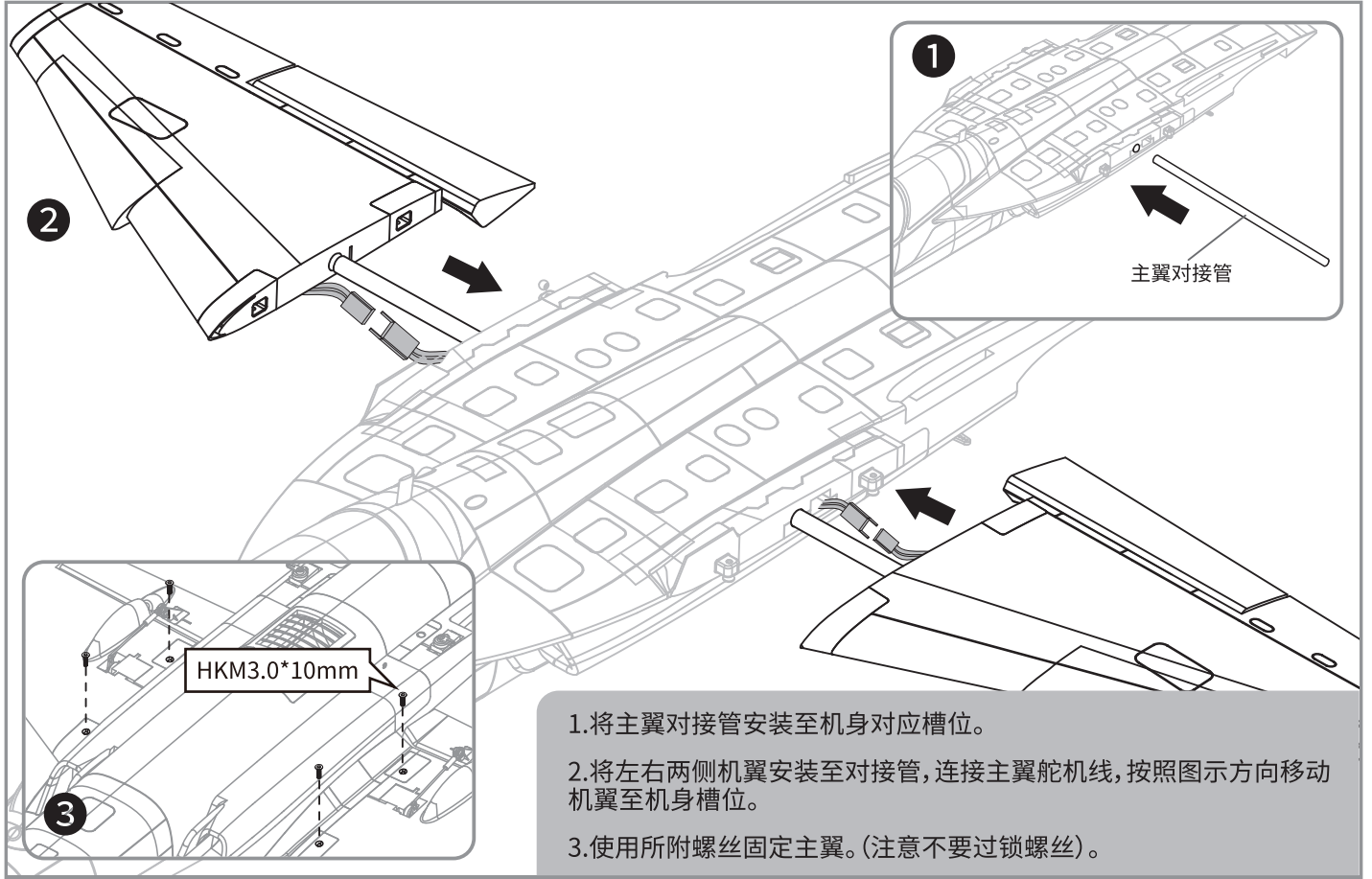

## 平尾安装

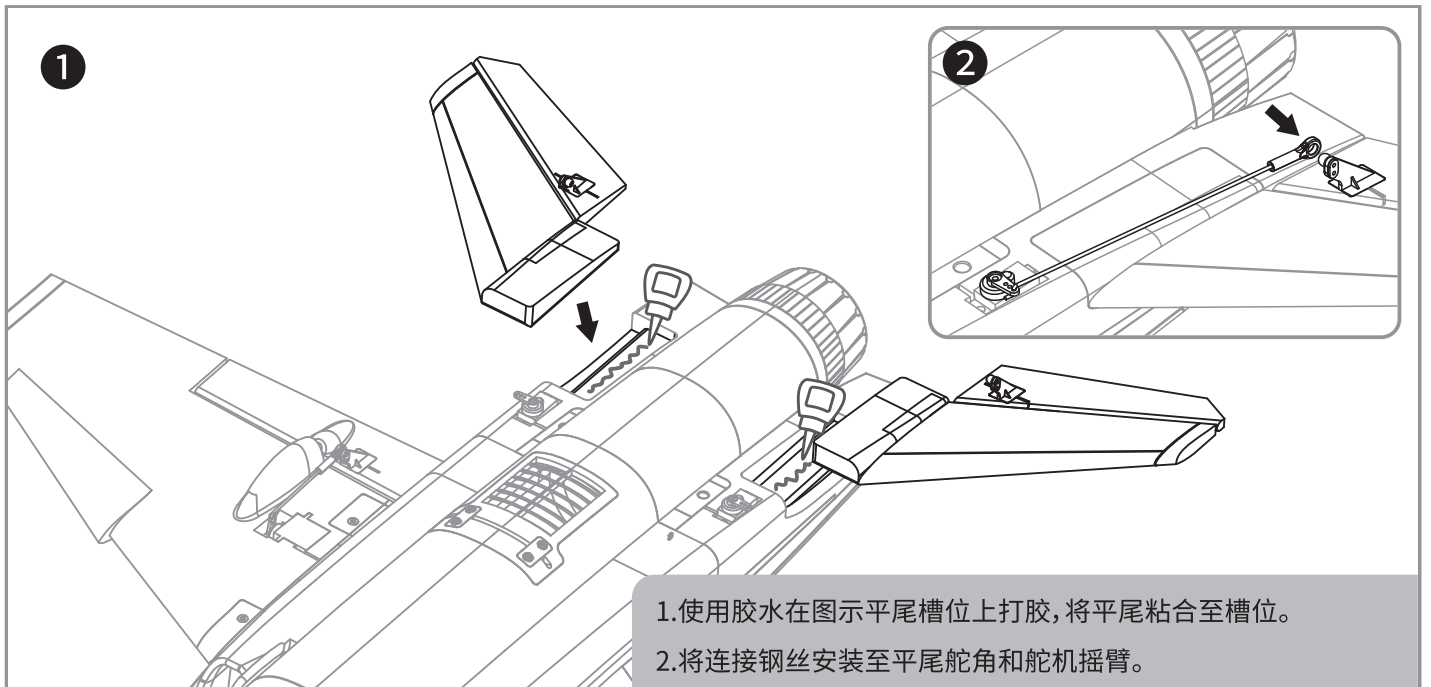

## 垂尾安装

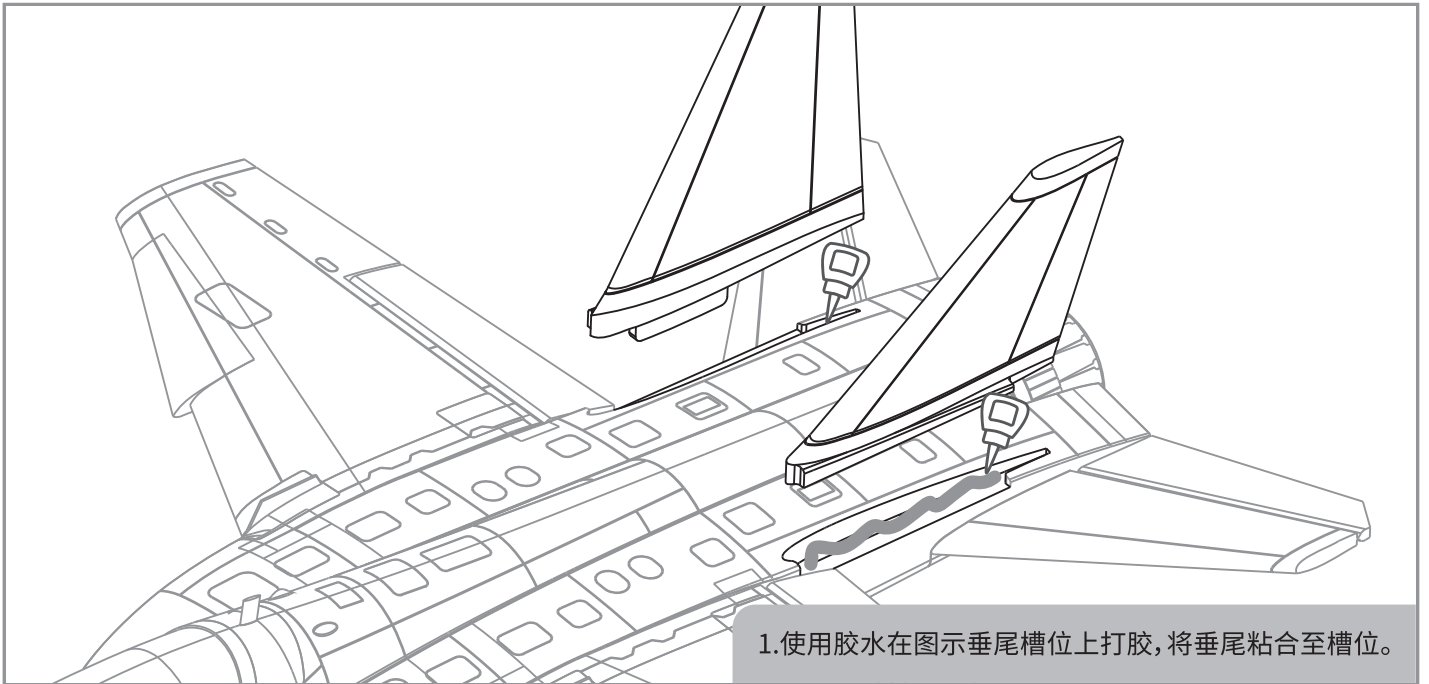

## 起落架安装

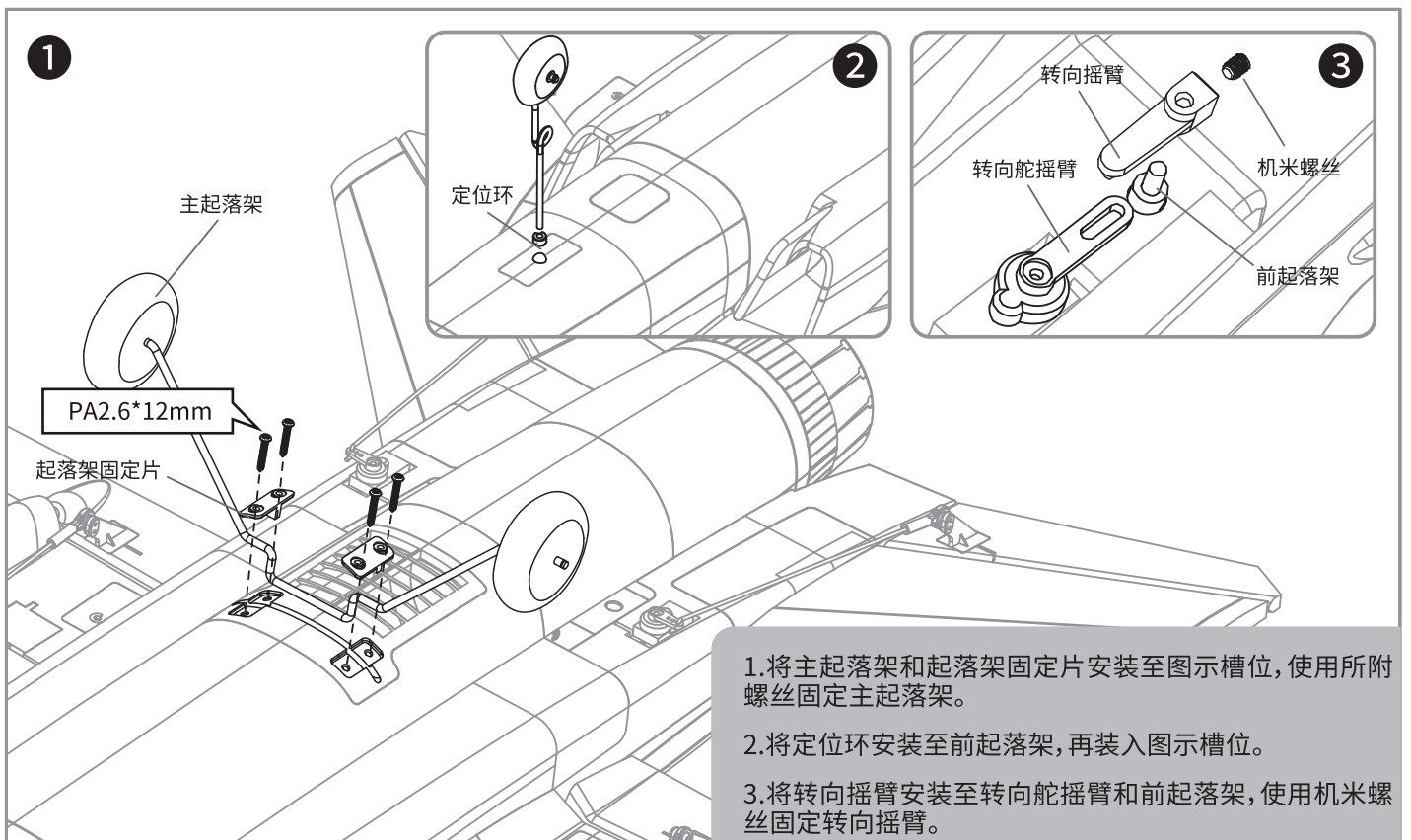

## 舵角摇臂安装

保证舵机为回中状态, 将连接杆调整到合适位置。

图示是舵角和舵面摇臂的出厂设置。

首飞建议用出厂设置的舵角飞行。

### 副翼舵机钢丝安装孔位参考

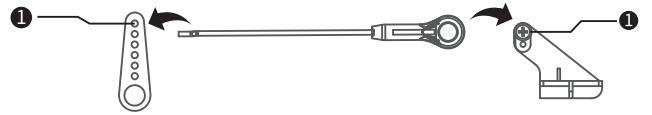

### 平尾舵机钢丝安装孔位参考

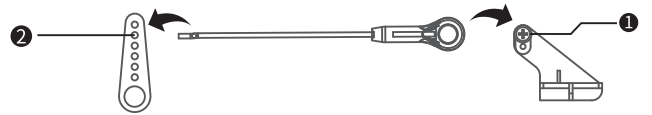

## 电池安装

1. 将电池与接收机连接前, 首先请打开发射机电源, 确认油门杆处于低位。
2. 移开电池仓罩, 取下电池板上的魔术带。
3. 将电池置于电池仓内, 有电源的线的一端朝向飞机尾部, 使用魔术带固定电池。
4. 由于不同的电池厂家生产的电池重量有差异, 需要调整电池的位置来平衡飞机的重心位置。

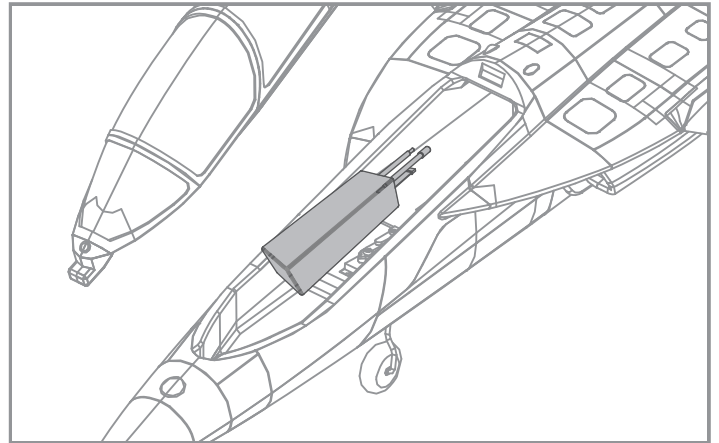

## 重心调整

**正确的重心, 直接关系到飞行的成功与否, 请参考下面的重心标示图来调整飞机的重心。**

— 您可以将电池向前、后移动来调整飞机的重心; 如果通过移动电池无法调整到正确的重心位置, 您还可以适当的使用一些其他材料来配重, 使得飞机的重心处于正确的位置。

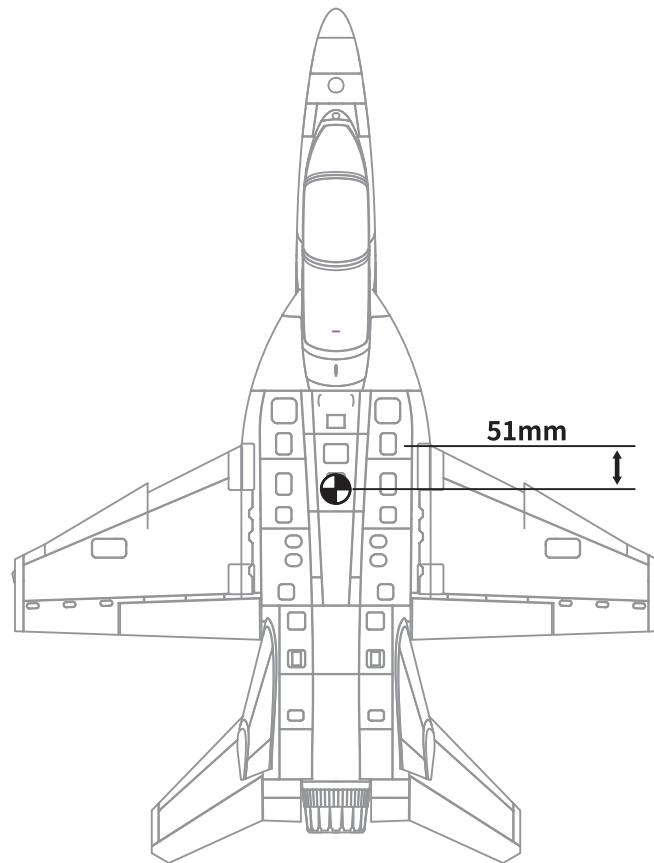

## 舵面测试

当您按照前面的步骤组装好飞机、调整好舵角摇臂后,在飞机起飞前,我们需要一块满电的电池连接到电调。用遥控器测试每个舵面的工作情况,检查是否正常!

注意:为保证安全,在测试舵面前,请务必拆下螺旋桨,以免电机意外启动发生事故。

副翼摇杆向左运动

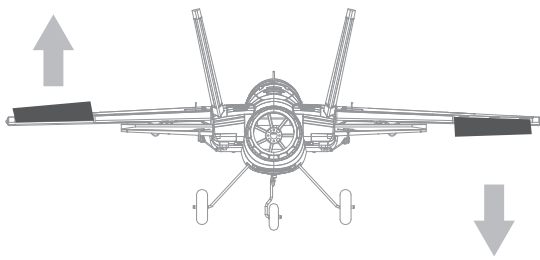

副翼摇杆向右运动

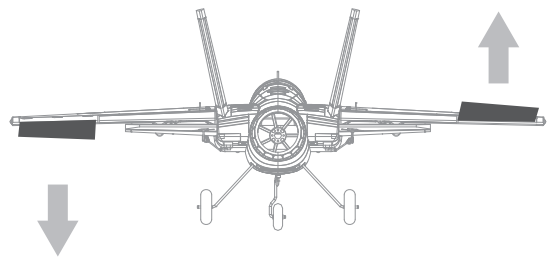

升降摇杆向下运动

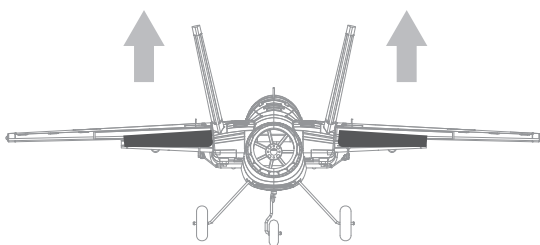

升降摇杆向上运动

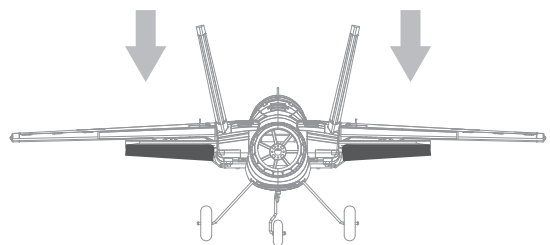

## 贴 纸 示 意 图

"NO STEP" 小贴纸出厂时不贴在飞机上,但附于包装盒内供玩家自行选择是否按图示位置贴上。

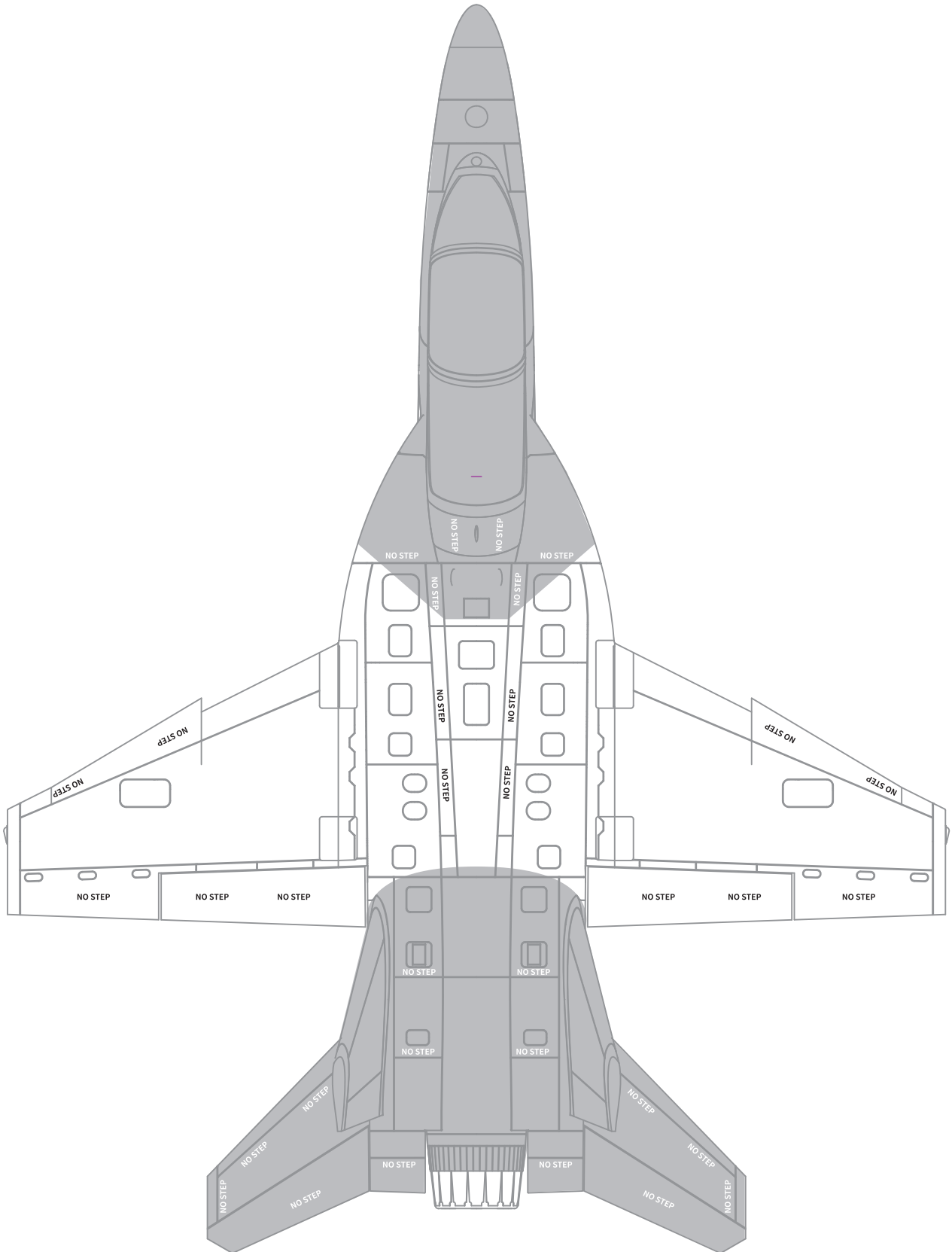

## \ 推荐舵面行程 /

根据我们的测试经验,我们认为按以下参数来设置大小舵量将更有助于飞行。小舵量飞机的操纵会显笨拙些,大舵量飞机的操纵会灵敏些,我们建议初次飞行使用大舵量起飞,然后视操纵习惯选用大舵量或小舵量飞行。

副翼

襟翼

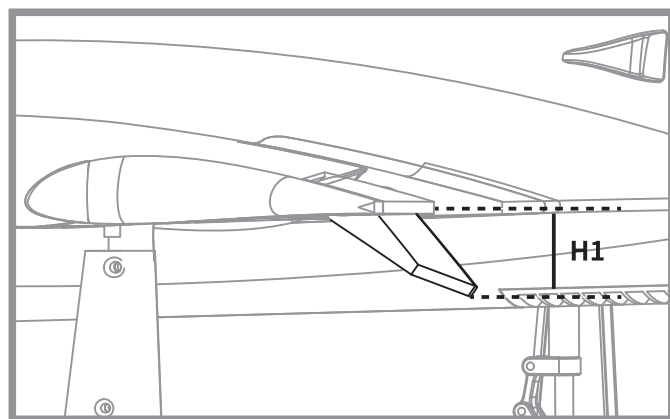
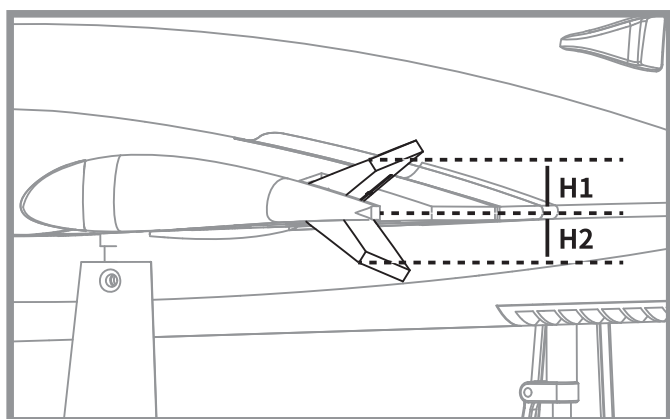

升降舵

方向舵

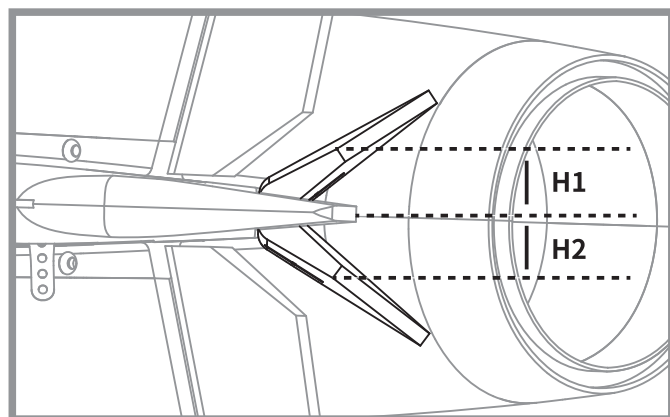
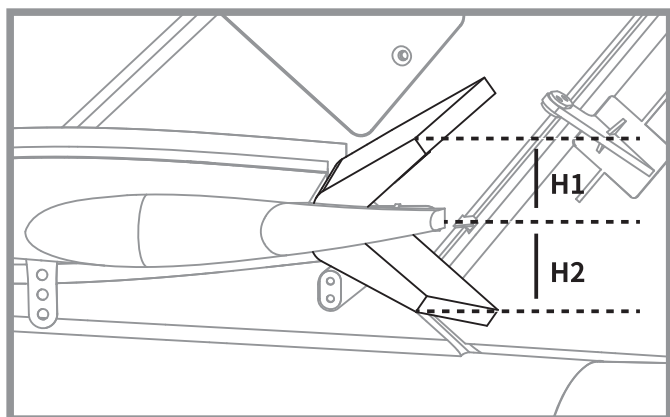

**飞行注意事项:**襟翼下放飞机有抬头现象,需要混控升降舵才能很好的降落,小舵量襟翼需要1mm降舵,大舵量襟翼需要2mm降舵。

	副翼	升降舵	方向舵	襟翼下放
小舵量(H1/H2)	8mm	8mm	/	/
大舵量(H1/H2)	12mm	12mm	/	/

## \ 故障检修 /

问题	问题原因	解决方式
油门推杆无响应,但舵机有响应	—电调未连接电机 —油门通道反向	—降低油门推杆和油门微调设定 —反过来重新装油门通道
桨的噪音过大或者震动过大	—桨罩、桨、电机、电机架坏了 —桨或者桨罩的小部件松动了 —桨装反了	—更换损坏的配件 —把桨、桨夹和桨罩的小部件拧紧 —反过来重新装桨
飞行时间变短,飞机无力	—电池电量低 —桨装反了 —电池坏了	—重新给电池充电 —依照电池说明书更换新的电池
飞舵面不动,或者动作响应较慢	—舵面、舵角、连接杆、舵机坏了 —连接线坏了或者接头松了	—更换或者维修坏了的配件 —检查所有连接线,确保所有接头无松动现象
舵面反向	—遥控器发射机通道反向	—检查通道控制(舵面)方向,调试飞机舵面和遥控器的舵面控制杆
电机无力	—电机或电池坏了 —电调用了不合适的低压保护装置	—检查电池、发射机、接收机、电调、电机是否有损坏(如有,请及时更换) —立刻操控飞机降落,重新给电池充电
接收器的LED灯慢闪	—接收器低电量	—检查电调和接收器之间的连接 —检查舵机是否受损 —检查连接杆是否安装到位

## \ 配件列表 /

XF103-01	机身	XF-DF002	64MM 空涵道12叶
XF103-02	主翼	XFKV3200	2840-KV3200电机
XF103-03	平尾	XFESC40A	40A电调
XF103-04	垂尾	XF SER9PP	9g塑胶数码正向舵机
XF103-05	座舱组		
XF103-06	轮胎组		
XF103-07	对接管		
XF103-08	连接杆		
XF103-09	螺丝组		
XF103-10	舵面摇臂组		
XF103-11	起落架组		
XF103-12	贴纸		
XFPILOT002	飞行员002		



# 空模无刷马达电子调速器(ESC)说明书

感谢您购买本产品！无刷动力系统功率强大，错误的使用可能造成人身伤害和设备损坏。为此我们强烈建议您在使用设备前仔细阅读本说明书，并严格遵守规定的操作程序。我们不承担因使用本产品或擅自对产品进行改造所引起的任何责任，包括但不限于对附带损失或间接损失的赔偿责任。

## 产品规格

型号	持续电流	瞬间电流	BEC类型	BEC输出	电池节数	重量	体积
Skywalker-6A	6A	8A	线性稳压	5V/0.8A	2节	5.5g	32*12*4.5
Skywalker-12A	12A	15A	线性稳压	5V/1A	2-3节	9g	38*18*6
Skywalker-12AE	12A	15A	线性稳压	5V/2A	2-3节	10g	38*18*7
Skywalker-15A	15A	20A	线性稳压	5V/2A	2-3节	16.5g	48*22.5*6
Skywalker-20A	20A	25A	线性稳压	5V/2A	2-3节	19g	42*25*8
Skywalker-30A	30A	40A	线性稳压	5V/2A	2-3节	37g	68*25*8
Skywalker-40A	40A	55A	线性稳压	5V/3A	2-3节	39g	68*25*8
Skywalker-40A-UBEC	40A	55A	开关稳压	5V/3A	2-4节	43g	65*25*12
Skywalker-50A-UBEC	50A	65A	开关稳压	5V/7A	3-6节	41g	65*29*10
Skywalker-50A-OPTO	50A	65A	无	无	3-6节	41g	65*29*10
Skywalker-60A-UBEC	60A	80A	开关稳压	5V/7A	3-6节	63g	77*35*14
Skywalker-60A-OPTO	60A	80A	无	无	3-6节	60g	77*35*14
Skywalker-80A-UBEC	80A	100A	开关稳压	5V/7A	3-6节	82g	86*38*12
Skywalker-80A-OPTO	80A	100A	无	无	3-6节	79g	86*38*12
Skywalker-100A-UBEC	100A	120A	开关稳压	5V/7A	3-6节	82g	86*38*12
Skywalker-100A-OPTO	100A	120A	无	无	3-6节	79g	86*38*12

## 产品功能简要说明(黑体字为出厂默认值)

1. 刹车设定：**无刹车**/有刹车。
2. 电池类型：**Lipo (锂电池)** / NiMH(镍氢)。
3. 电池低压保护模式：**逐渐降低功率**/立即关闭输出。  
注：低压保护时，将油门摇杆拉到最小油门的位置后即可重新启动马达，但因为此时仍处于低压状况，所以功率输出较小。
4. 低压保护阈值：**低/中/高**。
  - 1) 当电池类型设定为 Lipo 电池时，电调自动判断锂电节数，低/中/高情况下每节电池的截止电压分别为：2.85V/3.15V/3.3V。例如使用 3 节锂电，设定为中截止电压，则低压保护阈值为：3.15\*3=9.45V。
  - 2) 当电池类型设定为镍氢电池时，低/中/高情况下截止电压为开机时输入电压的 0%/50%/65%。0%意味着不进行低压保护。例如：使用 6 节镍氢电池，充满时电压为 1.44\*6=8.64V,当设定为中截止电压时，则截止电压阈值为：8.64\*50%=4.32V。
5. 启动模式：**普通**/柔和/超柔和启动，马达转速从静止到最高速度的时间分别为 300ms/1.5s/3s。  
普通启动适用于固定翼，柔和启动/超柔和启动适用于直升机。柔和启动和超柔和启动的初始转速都较低，即便瞬时油门摇杆推到最大位置，马达从静止到全速也分别需要 1.5 秒和 3 秒。  
(注：启动过程结束后若关闭油门，3 秒内再次启动，则均自动切换为普通模式，以免在特技飞行时因反应过慢而导致摔机)。
6. 进角：**低/中/高**，分别为 3.75 度/15 度/26.25 度。  
一般情况下，低进角可以适应较多的马达。但是因为马达结构差异很大，请试用各个进角以获得满意的驱动效果。为提高转速，可以将进角设为高进角。改变进角后，建议先在地面进行测试，然后再飞行。

## 首次使用您的无刷电子调速器

**特别强调！**为了让电调适应您的遥控器油门行程，在首次使用本电调或更换其他遥控器使用时，均应重新设定油门行程。

### 油门行程设定说明：

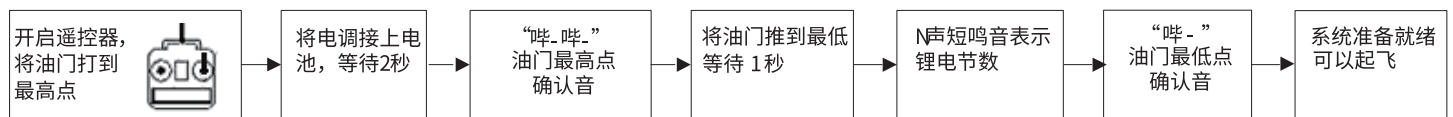

### 正常使用开机过程说明：

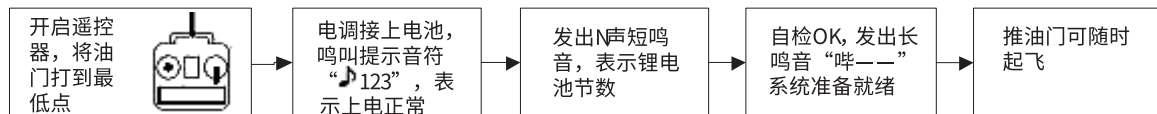

**电调保护功能说明**

1. 启动保护：当推油门启动后，如在两秒内未能正常启动马达，电调将会关闭马达，油门需再次置于最低点后，才可以重新启动。（出现这种情况的原因可能有：电调和马达连线接触不良或有个别输出线断开、螺旋桨被其他物体阻挡、减速齿卡死等）
2. 温度保护：当电调工作温度超过 110 摄氏度时，电调会降低输出功率进行自我保护，但不会将输出功率全部关闭，最多只降到全功率的 40%，以保证马达仍有动力，避免摔机。温度下降后，电调会逐渐恢复最大动力。
3. 油门信号丢失保护：当检测到油门遥控信号持续丢失 1 秒后，电调开始降低输出功率，如果信号始终无法恢复，则一直降到零输出（降功率过程为 2 秒）。如果在降功率的过程中油门遥控信号重新恢复，则立即恢复油门控制。优点：在油门信号瞬间丢失的情况下（小于 1 秒），电调并不会立即切断动力输出；如果遥控信号确实长时间丢失，则进行保护，但也不是立即关闭输出，而是有一个逐步降低输出功率的过程，给玩家留有一定的时间救机，兼顾安全性和实用性。
4. 过负荷保护：当负载突然变得很大时，电调会切断动力，或自动重启。出现负载急剧增大的原因通常是马达堵转。

**故障处理**

故障现象	可能原因	解决方法
上电后电机无法启动，无任何声音	电源接头接触不良	重新插好接头或更换接头
上电后电机无法启动，发出“哔-哔-、哔-哔-、哔-哔-”警示音（每两声之间的间隔时间为 1 秒）	电池组电压不正常	检查电池组电压
上电后电机无法启动，发出“哔-、哔-、哔-”警示音（每声之间的间隔时间为 2 秒）	接收机油门通道无油门信号输出	检查发射机和接收机的配合是否正常，油门控制通道接线是否插紧
上电后电机无法启动，发出“哔、哔、哔、哔、哔”急促单音	油门未归零或油门行程设置过小	将油门摇杆置于最低位置；重新设置油门行程
上电后电机无法启动，发出“哔-哔-”提示音，然后发出“567i2”特殊提示音	油门通道“正/反”向错误	参考遥控器说明书，调整油门通道的“正/反”向设置
电机反转	电调输出线和电机线连接的线序错误	将三根输出线中的任意两根对调

**使用遥控器编程设定说明**

使用遥控器油门摇杆设定参数分为四个步骤：

- 一. 进入编程
- 二. 选择设定项
- 三. 选择设定项下的参数值
- 四. 退出

注意：务必检查遥控器中油门曲线的设置，确保摇杆最低点位置对应的油门输出值为 0，最高点位置对应输出值为 100%

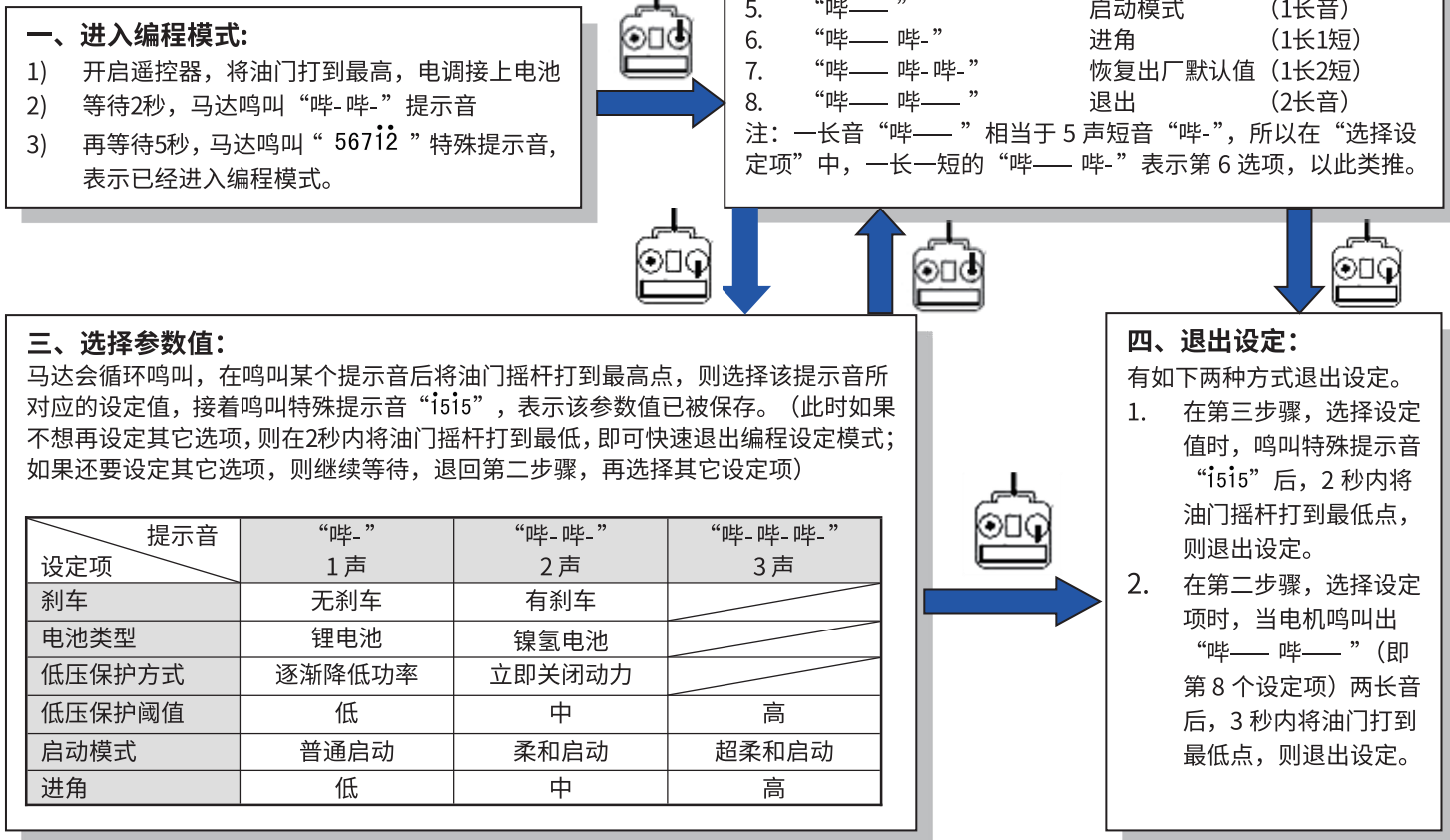



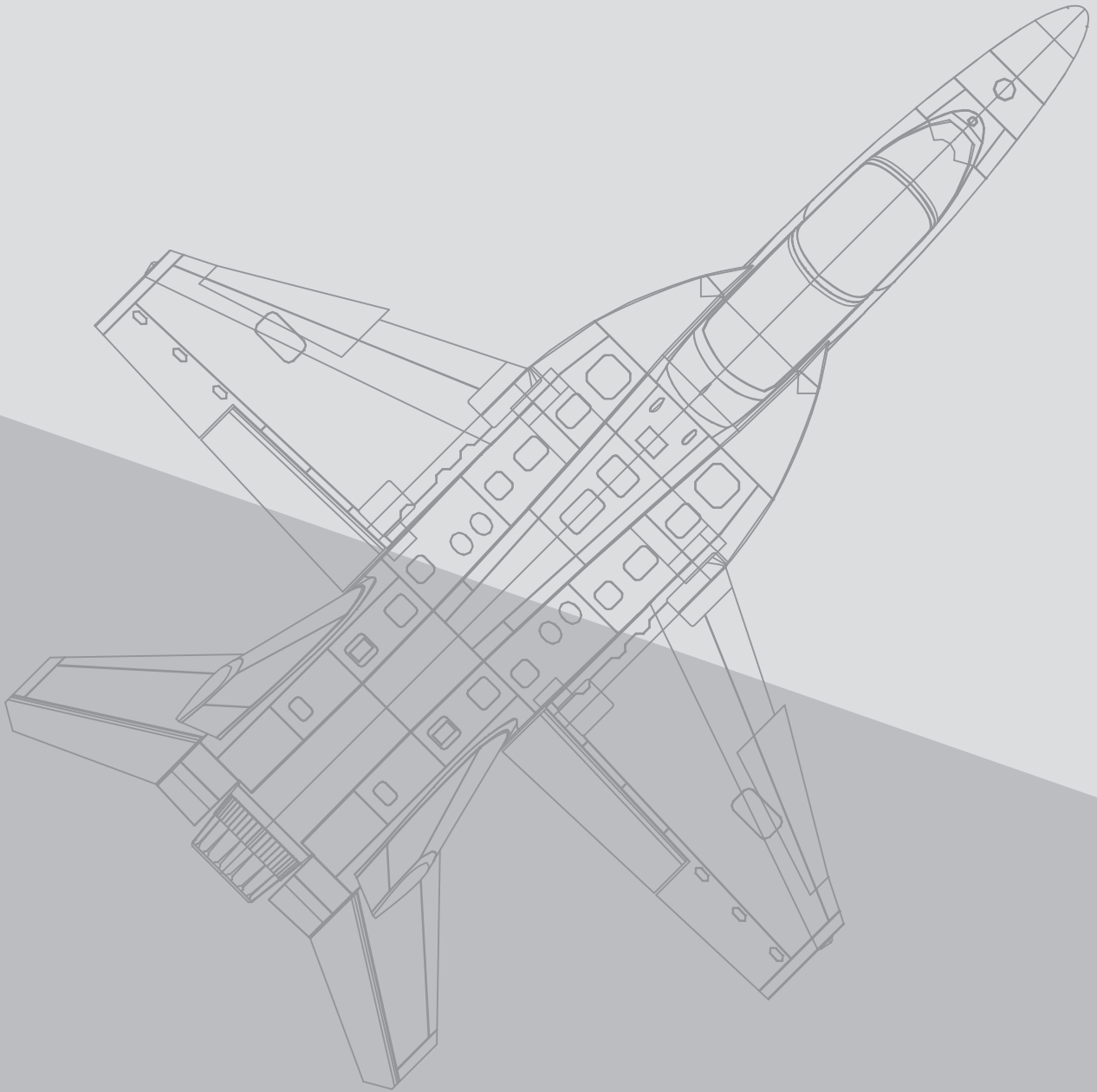

**XFLY-MODEL**



Dongguan Xfly-Model Technology Co., Ltd  
URL: <http://www.xfly-model.com/>  
E-Mail: [support@xfly-model.com](mailto:support@xfly-model.com)

东莞市迅飞航空科技有限公司  
网址: <http://www.xfly-model.com/>  
邮箱: [support@xfly-model.com](mailto:support@xfly-model.com)